

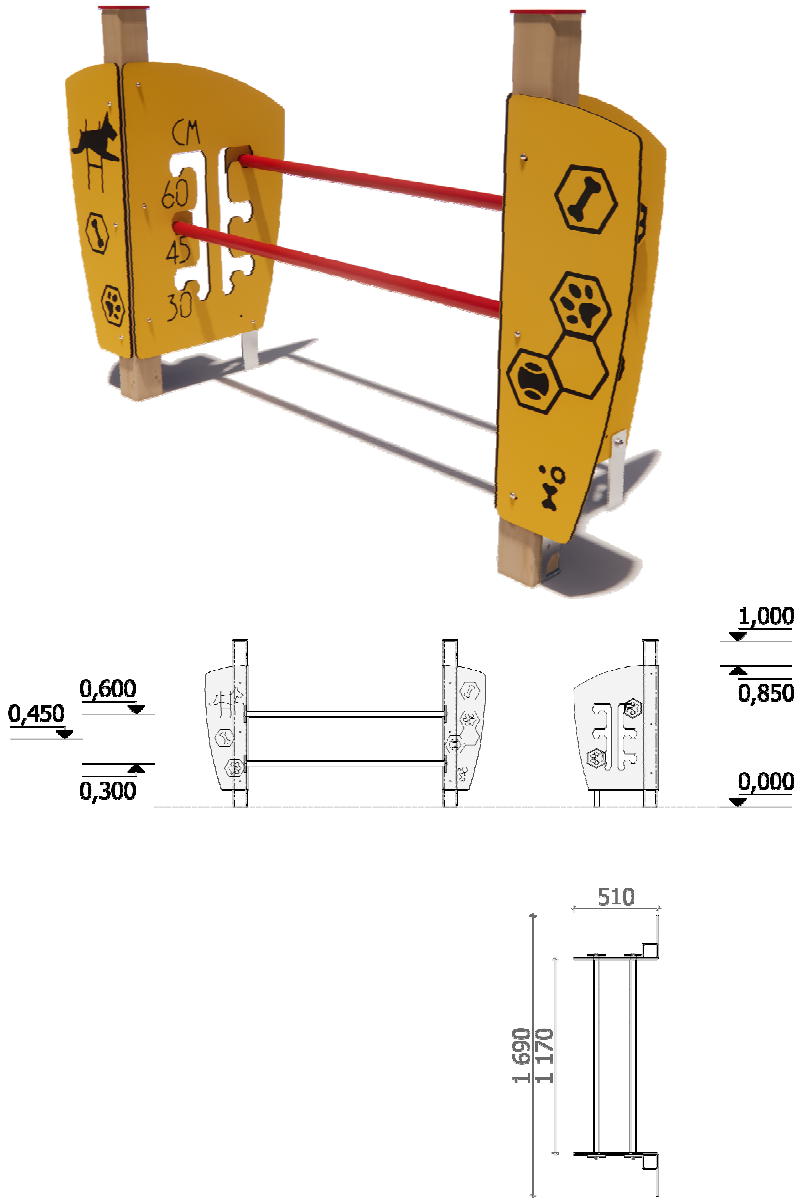

STL008

PRODUCT DATA SHEET

SIA "Jūrmalas Mežaparki"
 1 Garkalnes street, Jūrmala
 +371 6773 2317, www.jmp.lv



Category:



Parameters:

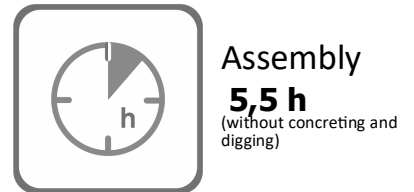
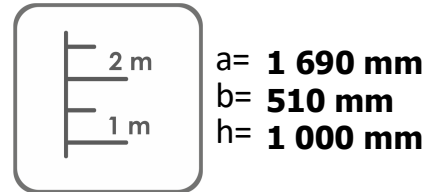

Used materials:

- * Glued pine wood beam - impregnated (green); Impregnated board;
- * Three-layer HPL (high pressure laminate);
- * Water-resistant, abrasive plywood;
- * Stainless steel;
- * PP (poppropylene);

Concrete:

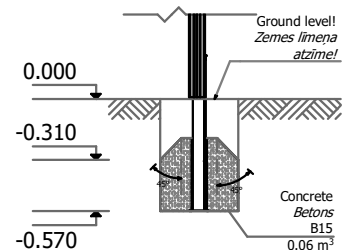

Spare parts availability: The spare parts and spare parts can be purchased at SIA "Jūrmalas Mežaparks". factory within 3 days after the customer's request after warranty period. Spare parts are available for 10 years. erves share availability.

Requirements: The equipment-agility may only be used after two days when the concrete is completely dry. The equipment-agility is fixed (mounted) at the installation site

Transportation:

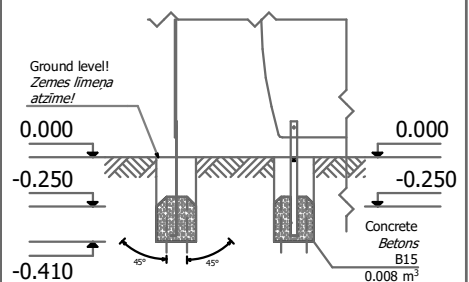

In production since:
19.05.2022.

SIA "Jūrmalas Mežaparks" reserves the right to change the items described in this document without prior notice.

Manufactured according:

