

Construction is made from massive wood, stainless and galvanized steel metal.

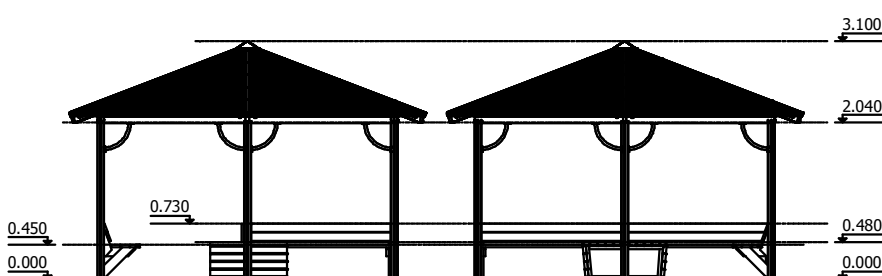

< 25
children

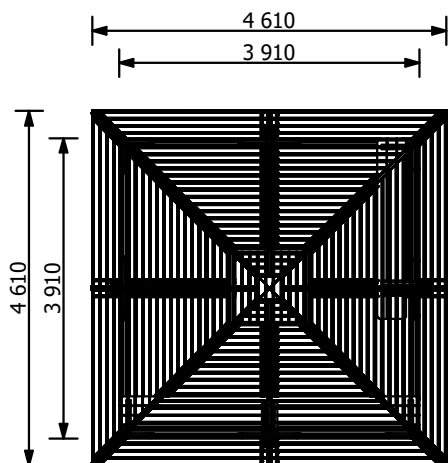
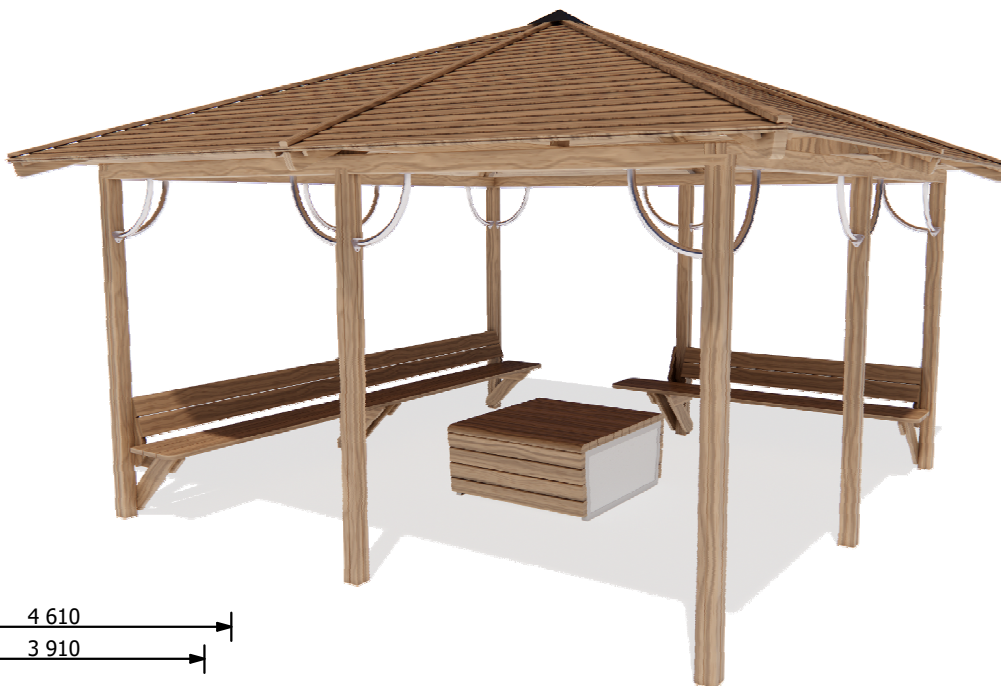

8 h
(without excavation and
concreting)

Length: **3 910 mm**
Width: **3 910 mm**
Height: **3 100 mm**
Equipment footprint: **15,27 m²**

The canopy is fixed on a pre-prepared and concreted concrete foundation at the installation site. The canopy may only be used after two days, when the concrete has completely hardened and the equipment is fully installed. During assembly and concreting, children must not be in the safety zone!

Safety checks must be carried out:

once a week or daily in areas with a high risk of vandalism to ensure that they are in good condition.

Maintenance is required:

once a season, i.e. once every 1 - 3 months. depending on the frequency of use.

Spare pieces:

All needed spare parts and elements, when warranty time expires can be ordered in Jūrmalas Mežaparki Ltd., and all the goods will be ready for delivery in 5 working days.